

Safety Flasher

This circuit alternately flashes two high-brightness LEDs as a safety measure during jogging or walking. The LED's can be mounted on clothing or a belt. The circuit draws a precisely controlled 10mA in order to conserve battery life. Also, the battery voltage can drop to the LED voltage plus about .5 volts before there is a noticeable change in performance.

The LEDs actually act like voltage regulators. Because the blue LED has a higher drop voltage, it will dim rapidly and then go out first (about 3 volts) with decreasing battery voltage. The yellow LED will keep blinking unaffected to about 2 volts of battery voltage. Also due to the higher voltage drop of the blue LED, the blue LED is on for less time than the yellow LED at normal battery voltage.

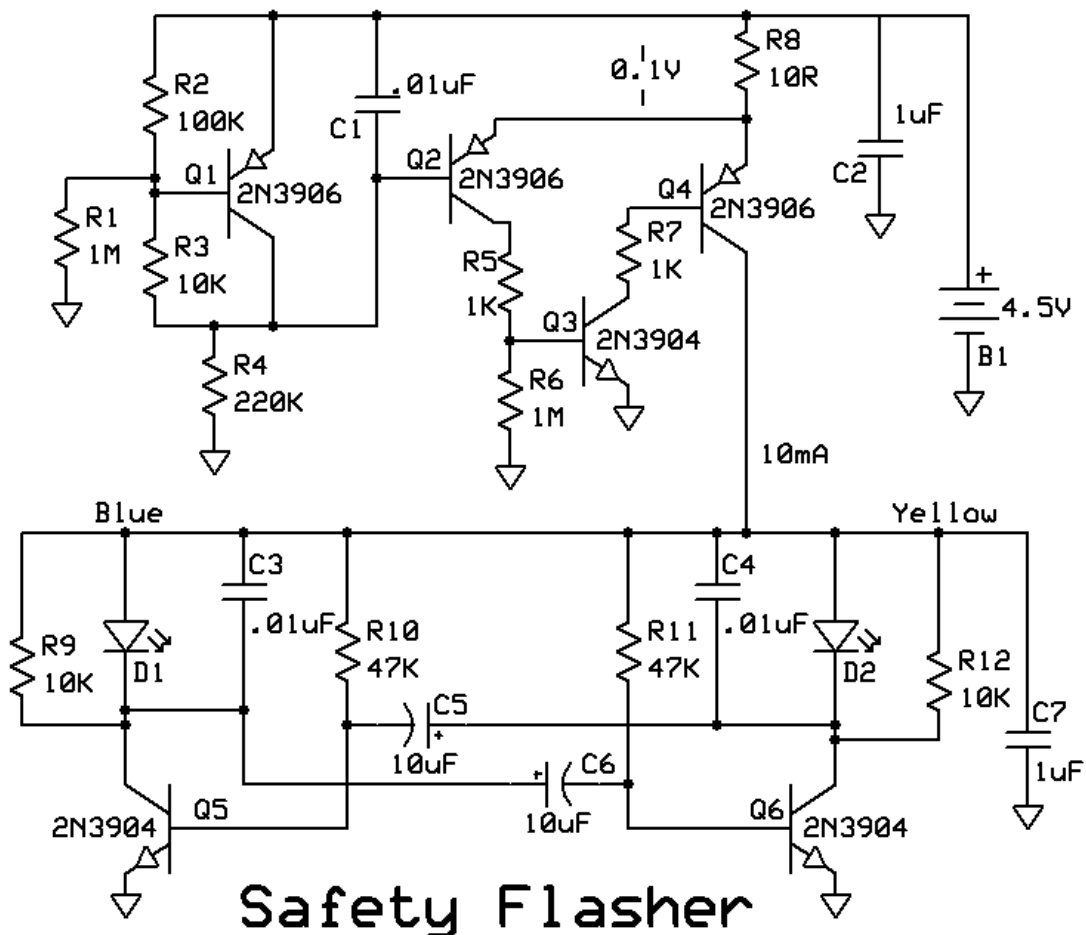

Safety Flasher

Andrew Morris marr3763@bellsouth.net

The circuit is built into a Radio Shack 4 AA cell battery holder with switch (RS P/N 270-409). The battery compartment farthest from the switch was used for the electronics. C2 and C3 were added because the long wires I used for the LEDs caused instability of the flasher circuit. I admittedly went overboard with the LED wires.

