

VOLTAGE CONVERTER

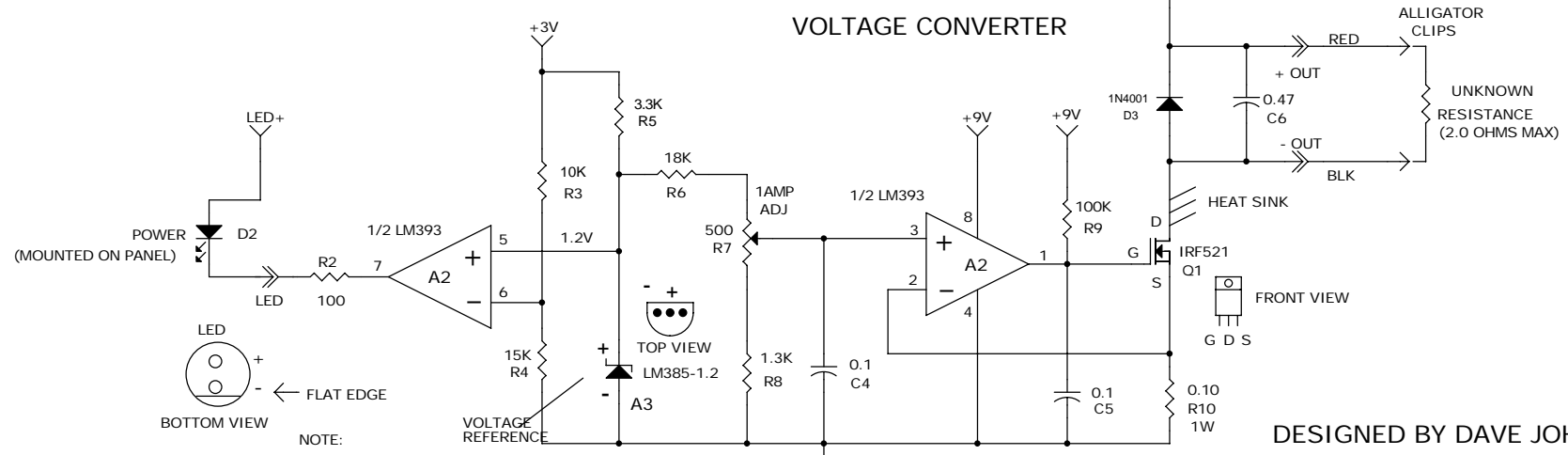

NOTE:
 POWER LIGHT WON'T STAY ON IF BATTERY VOLTAGE DROPS BELOW 2V
 DON'T OPERATE UNIT MORE THAN 10 SECONDS AT ONE TIME

DESIGNED BY DAVE JOHNSON
 DISCOVERCIRCUITS.COM
 ALL RIGHTS RESERVED

DRAWN BY DAVE JOHNSON

1 AMP CURRENT INJECTOR

DAVID JOHNSON AND ASSOCIATES		
1 AMP CURRENT INJECTOR CIRCUIT		
Size B	Document Number INJECT01.DSN	Rev A
Date: Tuesday, July 11, 2006	Sheet 1	of 1